

INTELIGENTNÍ TECHNOLOGICKÉ SYSTÉMY PRO SKLADOVÁNÍ A DOPRAVU MATERIÁLU (PALIVA)

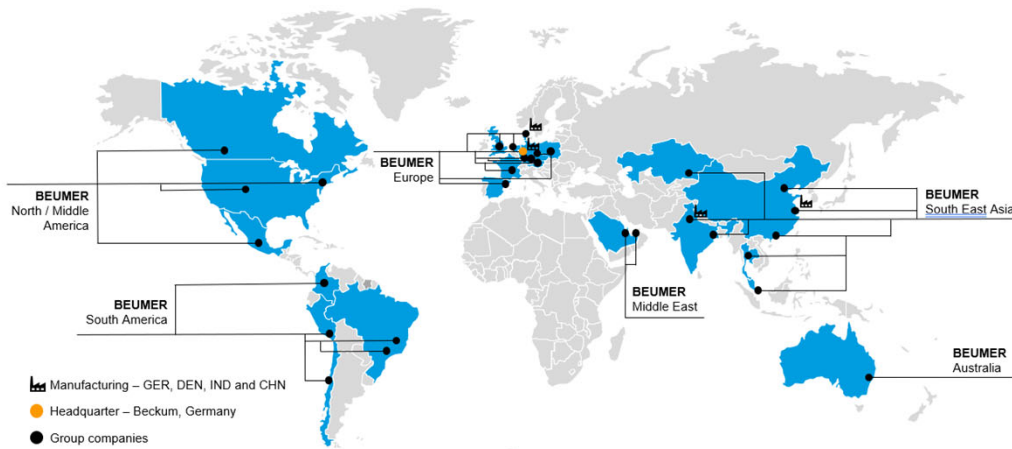

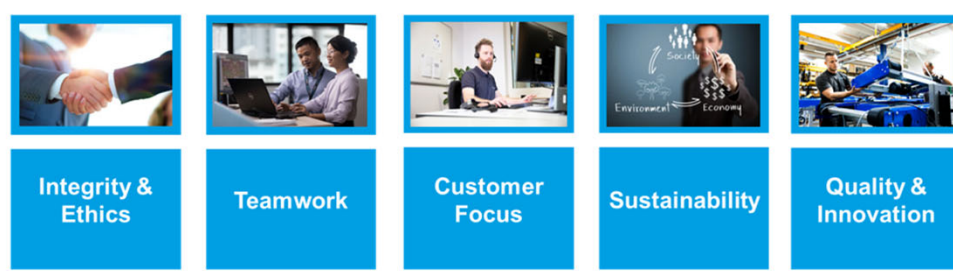

MADE DIFFERENT



Integrity & Ethics

Teamwork

Customer Focus

Sustainability

Quality & Innovation



90 years on the market



- Company founded in **1935**
- Independent, privately owned in 3rd generation
- Annual turnover of about **1.4 billion EUR**
- + 5,950** employees
- Strong global setup
- More than **40 group companies**

Průmyslová odvětví



“Usilujeme o dlouhodobý úspěch,
nikoli o krátkodobý zisk”.

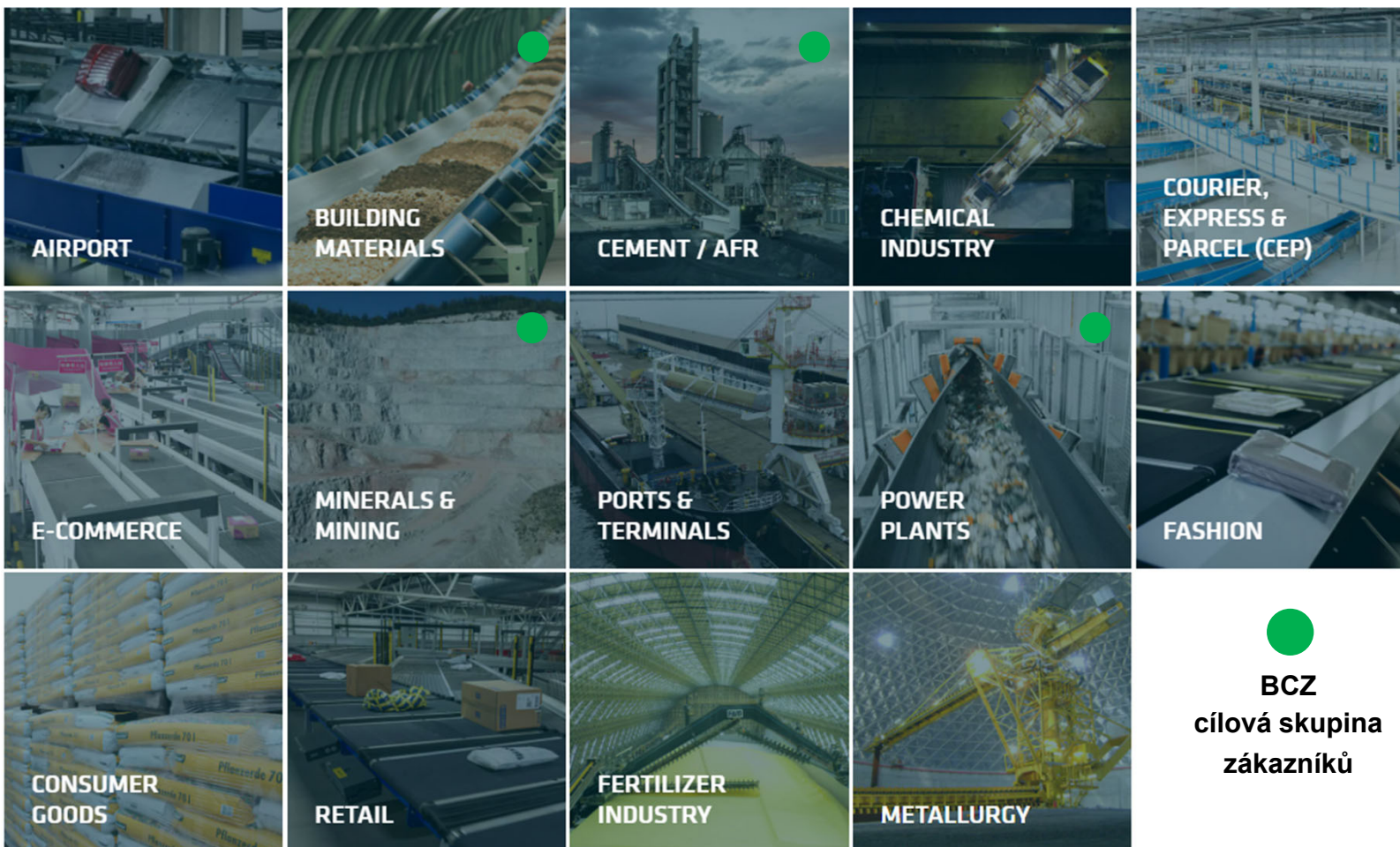

BCZ
cílová skupina
zákazníků



Základní informace

- Kanceláře: Ústí nad Labem, Chrudim, Praha
- 72 zaměstnanců
- Technická podpora, dodávky pro BEUMER Group

Speciální zaměření

- Systémy pro manipulaci se sypkými hmotami alternativními palivy a zpracování odpadu
- Mechanické dopravní a přepravní systémy
- Manipulace s volně loženými materiály
- Modernizace a řešení šitá na míru zákazníkům

Svoz odpadu

AF Příprava Partnerství, spolupráce

AF Manipulace Klíčové dodávky

AF Spalování Spolupráce

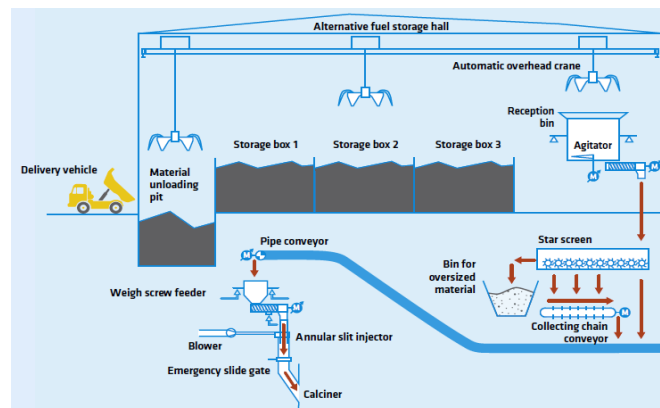
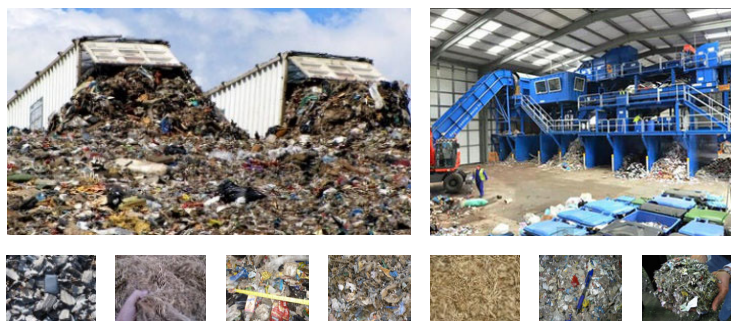

Řešení pro skladování, dávkování a manipulaci AF



Kalcinátor - doprava,
dávkování

Hlavní hořák - doprava,
dávkování

Příjem paliva,
skladování, doprava

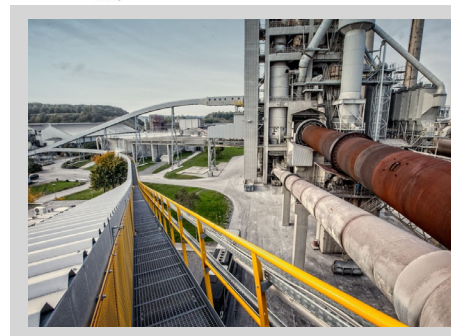
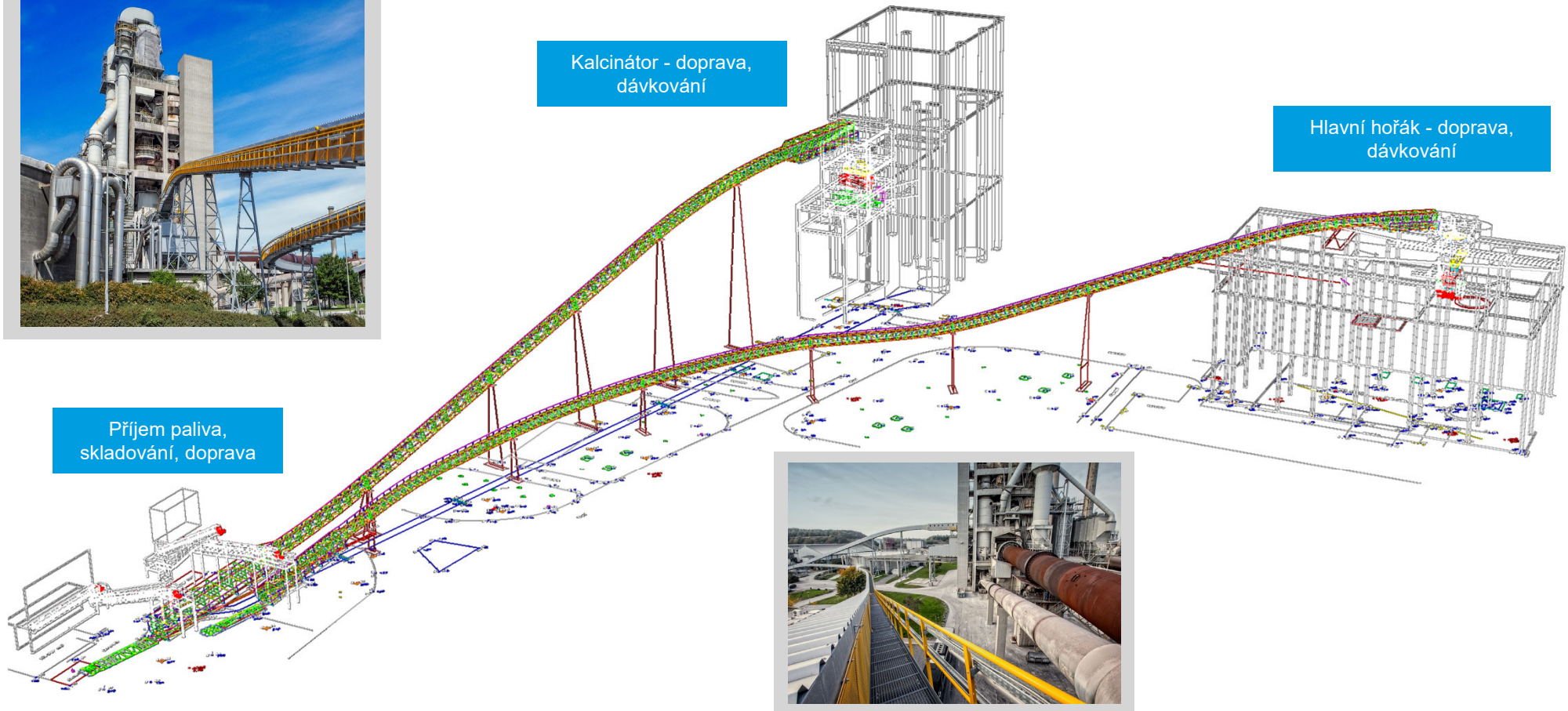

Portfolio

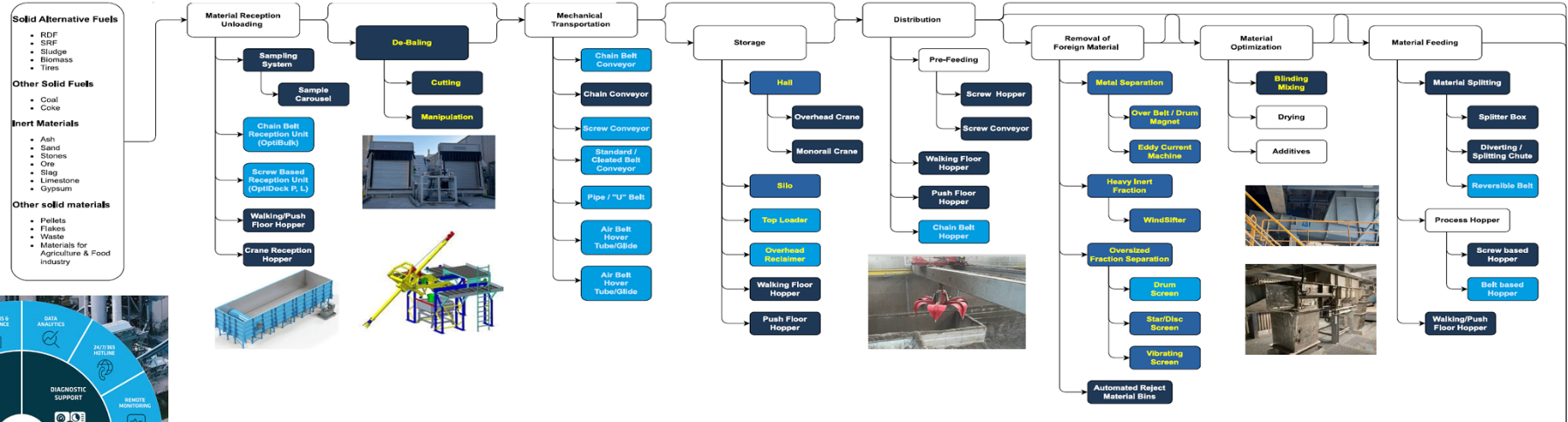

- Options Available on Items**
- Fire Protection Systems
 - Hotspot Detection with Infrared Camera/Sensor
 - Spark Detection and Suppression Activation Systems
 - Continuous Air Monitoring for Combustion Gases
 - Suppression Systems in Spot or Flooding Design
 - Water, Water-Foam, Inert Gas available for suppression
 - Explosion Protection
 - Explosion Pressure Design - 500mbar to 10bar
 - Explosion Detection, Isolation, and Propagation Mitigation
 - Relief Panel, Flameless Relief Valves
 - Wear Resistant Construction
 - Wear Resistant Material for Highly Erosive Material
 - Alloy Steels for Chemically Corrosive Material
 - Additional Custom Modifications for Each Material Handled
 - Site services & Site deliveries for the parts that should be managed during the site service – pipeline, chutes, site management

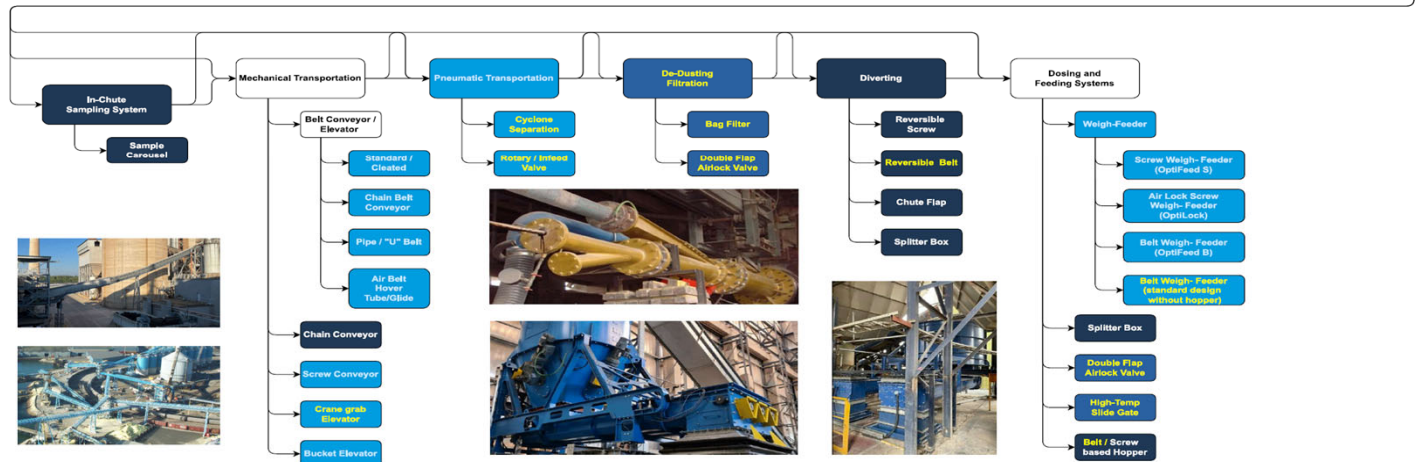

MADE DIFFERENT

Produkty a jejich využití



Calciner Feeding



BG OptiLock



Screw Conveyor



BG OptiFeed B



BG OptiValve SG

Main Burner Feeding



BG OptiFeed S



BG OptiFeed Ex



BG OptiFeed



BG OptiFeed Duo

Mechanical Transport



Chain Belt Conveyor



Drag Chain Conveyor



HoverTube



Bucket Elevator



Belt Conveyor



HoverGlide

Reception & Storage



BG OptiMac



BG OptiBin MF



BG OptiDock



Storage - Silo



BG OptiBulk

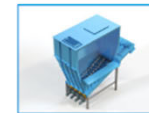

BG OptiBin S

Doprava alternativních paliv – klíčové produkty

Mechanická doprava (vzdálenosti 5 – 200 m)

Standard troughed-belt conveyor



Mechanická doprava (vzdálenosti 50 – 5000 m)

Pipe (tube) conveyor

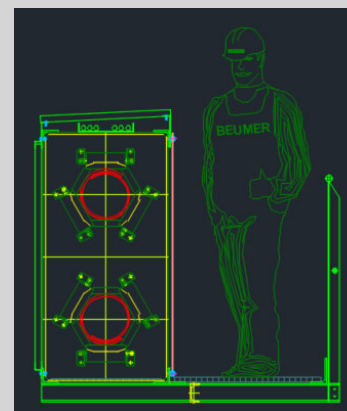

U-shaped belt conveyor

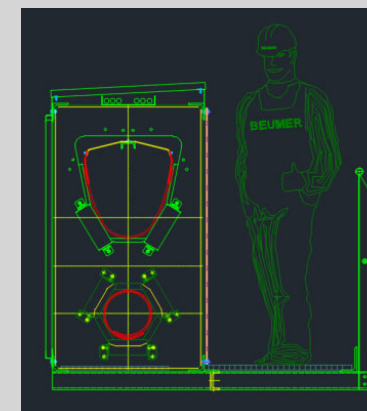

Mechanická doprava

Modulární konstrukce: různé kapacity a přepravované materiály, konstrukce odolná vůči výbuchu s mnoha referencemi a zkušenostmi z aplikací

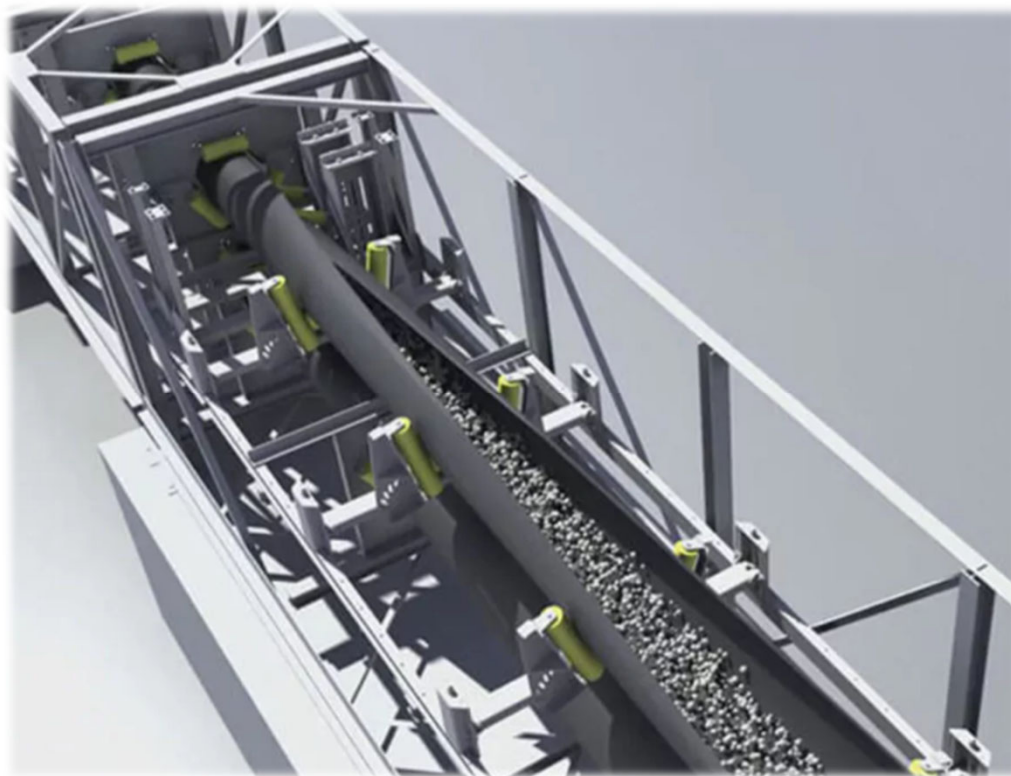

Doprava alternativních paliv

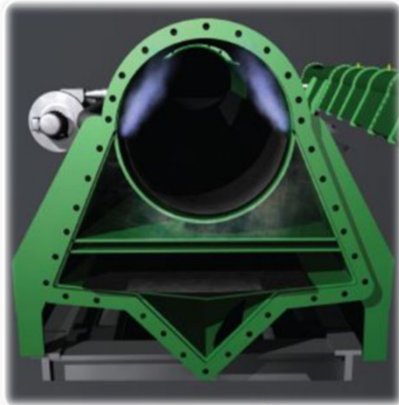

BG HoverTube

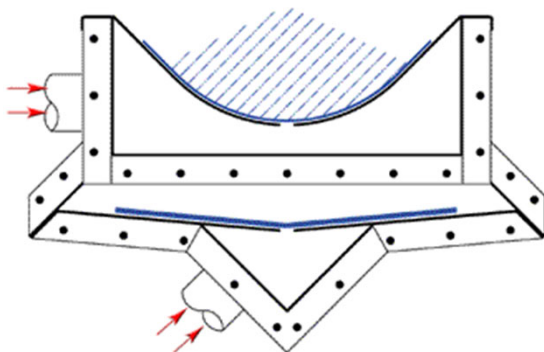

BG HoverGlide

Dopravník na vzduchovém polštáři



Doprava alternativních paliv

Korečkové elevátory

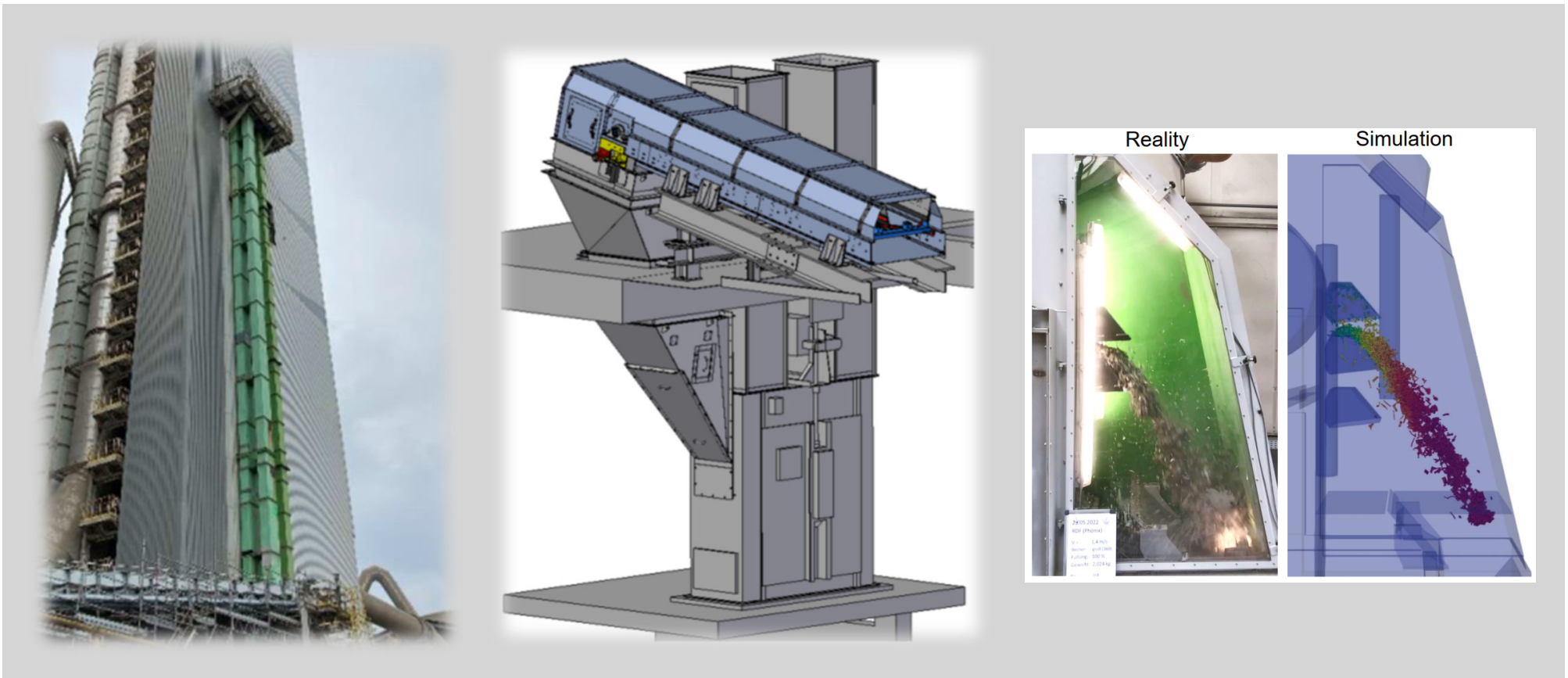

Technologie příjmu materiálu – flexibilní řešení

- ❖ Různé typy vykládacího mechanismu – šnekový, řetězopásový, pohyblivá podlaha atd.
- ❖ Řada funkcí – provozní násypka, gravimetricko-volumetrický podavač, dělicí násypka, uzavírací násypka

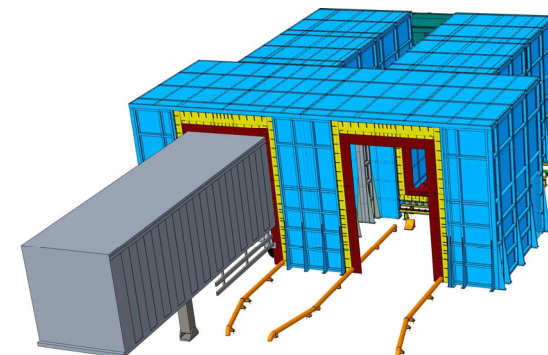
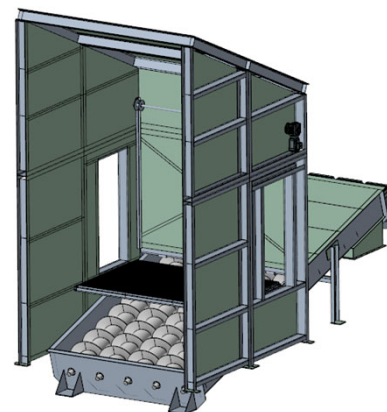
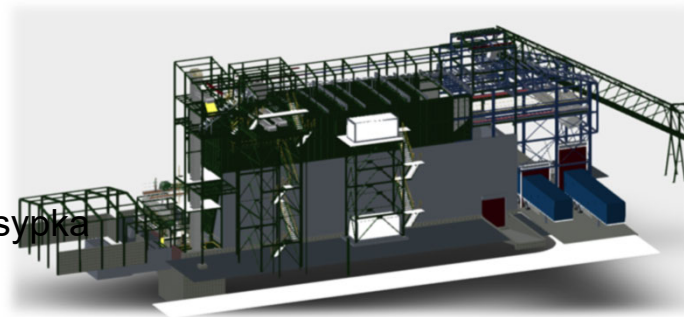

Příjmové vykládací stanice

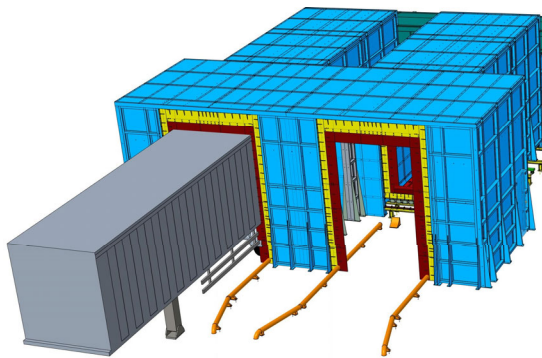

Technologie příjmu a skladování



Automatický jeřáb, posuvná podlaha, vzorkování, skladování paliva

Příjem paliva do přivážecí jámy nebo přímo na posuvnou podlahu



Technologie dávkování alternativních surovin



Technologické uspořádání

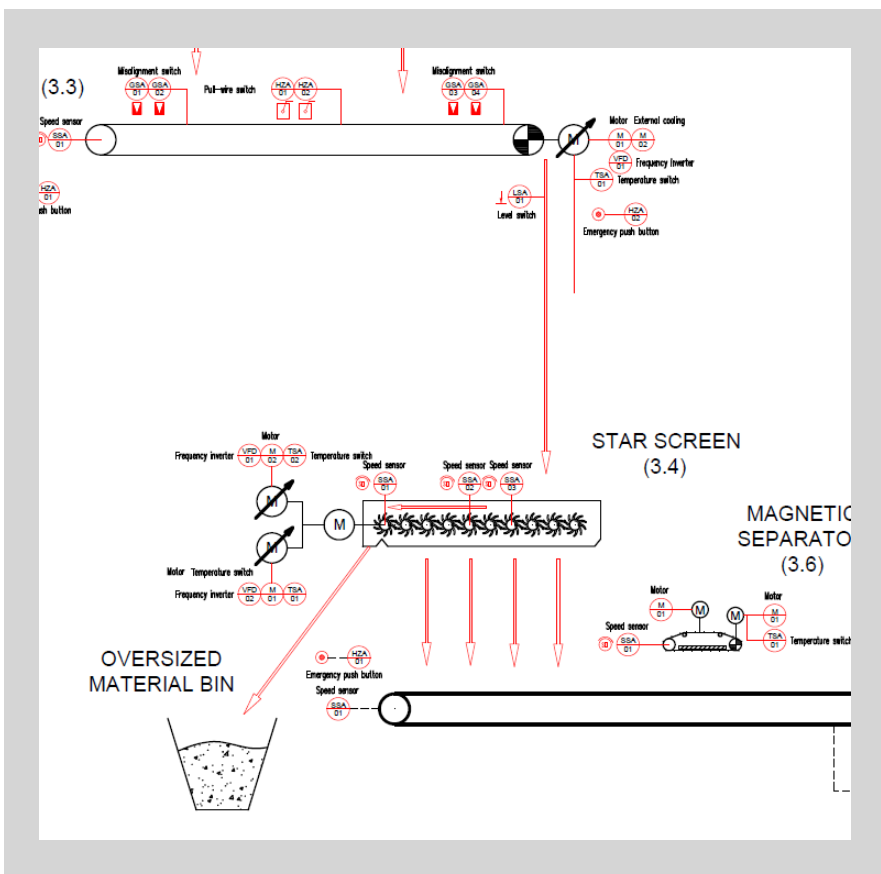

Technologické testovací centrum Přestanov



Kompletní technologická řešení

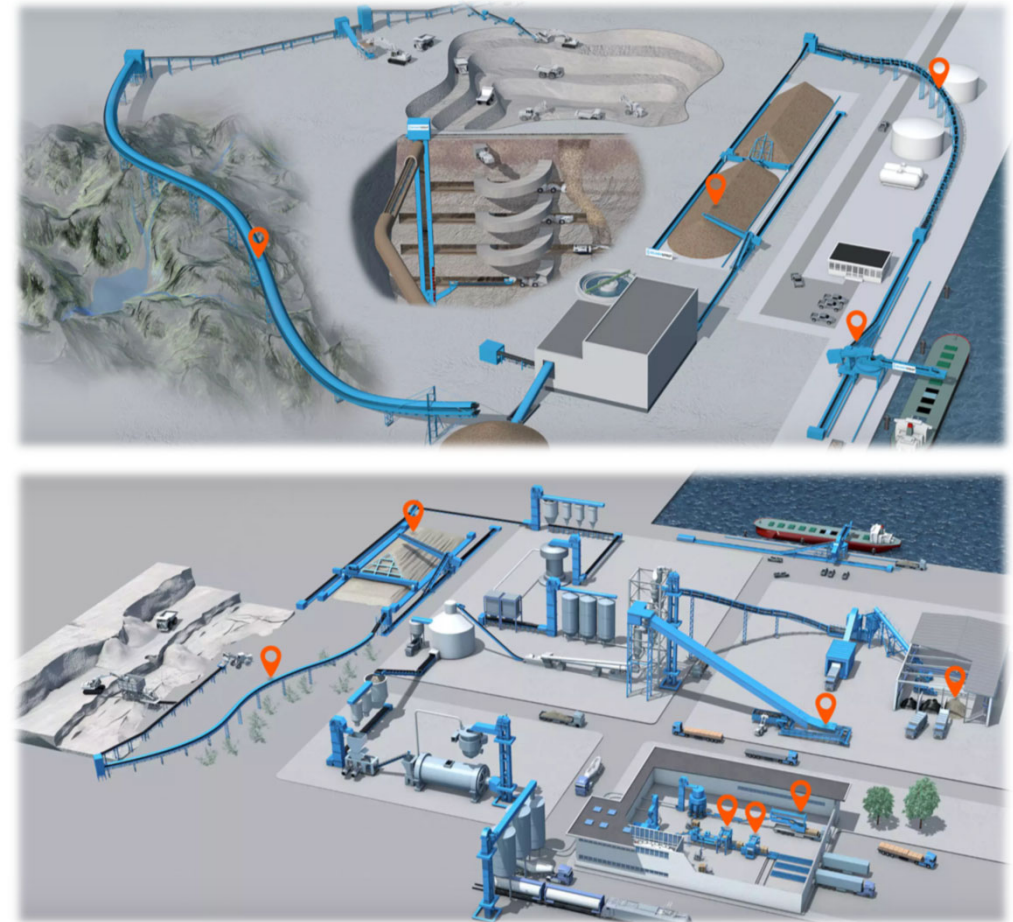
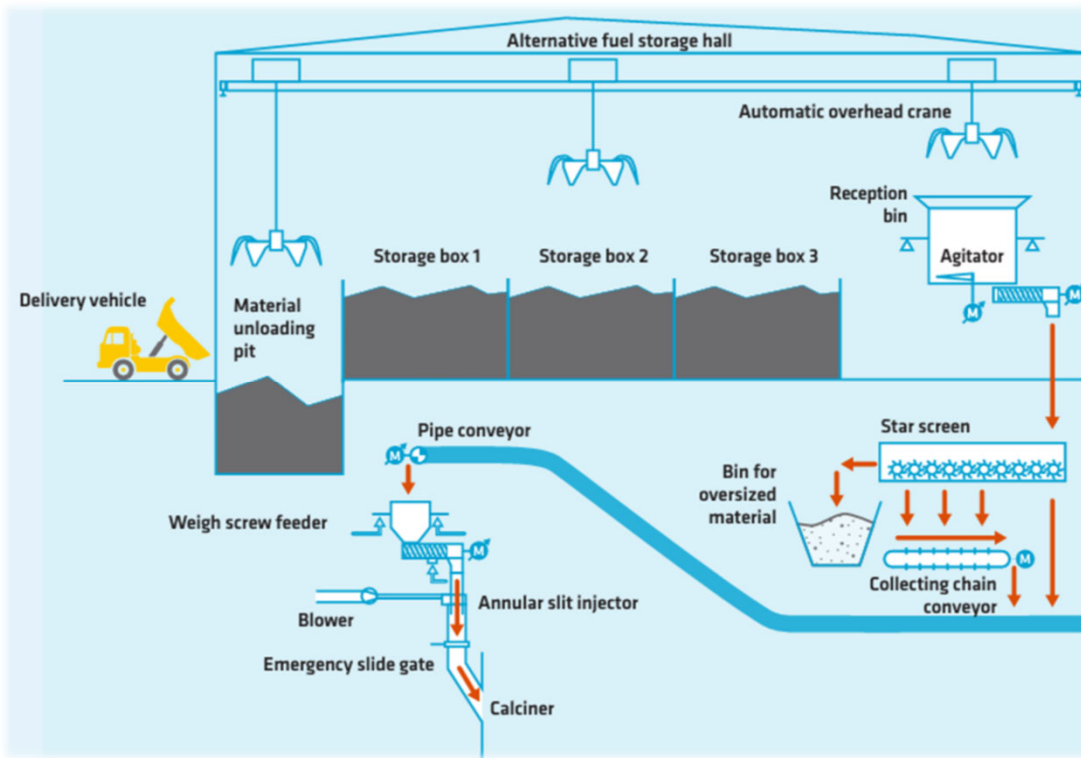

MADE
DIFFERENT

BEUMER GROUP



Děkujeme za Vaši pozornost



Aleš Bednář
+420 739 441 903
ales.bednar@beumer.com

MADE
DIFFERENT